

PST 50-80 STANDARD GUIDE

Guides for installation and later handling of pumps and submersible mixers in intermediate pumping stations and wastewater treatment plants. Standard guides have a very simple design and are very easy to operate. They are often used in the case of guide installations in closed hatches. They require an additional machine for lifting and lowering of mixers, e.g. cranes.

Functions:

- installation of mixers at a workstation,
- lifting of machines to maintenance position,
- regulation and establishing the orientation and height of mixer operation

Guide type	PST - standard (under hatch)			Unit of measure
	50	60	80	
Size	50x50	60x60	80x80	mm
Column profile (square)	50x50	60x60	80x80	mm
Profile wall thickness	2	3	3(4)	mm
Guide weight (without column)	3	4.5	7	kg
Guide column feet	H – horizontal, V- vertical, R– regulated			
Maximum mixer power	2.2	3.0	7.5	kW
Maximum mixer weight	50	75	100	kg
Supported mixer types	MZ 03-22	MK 15-38	MK 40-55	-

The data above should only be used in conjunction with up to date and detailed information on www.biox.pl.

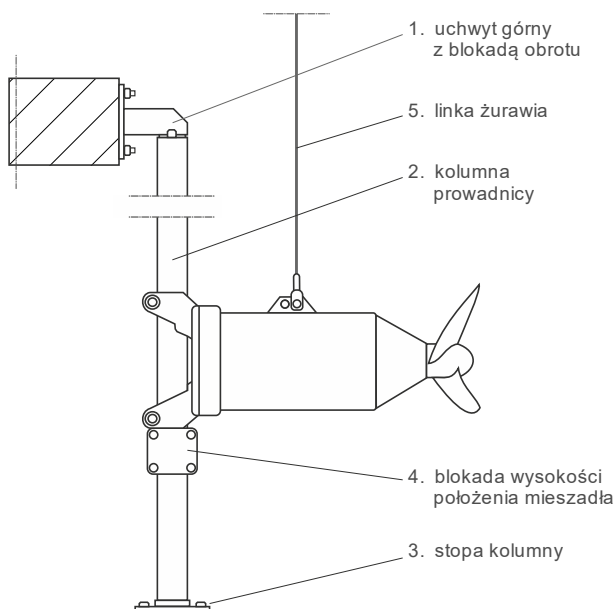

od 1989

mieszadła



natleniacze



dekantery



zbieracze



żurawiki



prowadnice



wciągarki