

MZP 03-22 HYDRA PUMPING MIXERS

Small submersible mixers adapted for operation as rotor pumps in installations requiring high performance, with a small lifting height. They can work as pumping mixers after installation on coupling flanges supported by PMP guides with the use of service cranes.

Functions:

- pumping of liquid in pipelines
- pumping of liquid between tanks on the same level.

Mixer symbol	MZP03.8	MZP05.8	MZP10.6	MZP15.4	MZP20.4	Unit
Mixer power	0.37	0.5	1.1	1.5	2.2	kW
Revolutions	700	675	920	1405	1410	rpm
Rotor diameter	190-240					mm
Rotor type	rotor, tri-blade, self-cleaning					-
Pipeline size (DN)	200-250 (300)					mm
Pumping capacity	100	120	225	300	380	m ³ /h
Material	cast iron or stainless steel body					-
Seals	two-level mechanical sealing with oil chamber					-
Supply voltage	3x400					V
Weight	26.1	26.1	26.5	26.9	29.3	kg
Power cable	length 6m (longer cable available upon request), standard or					-
Recommended equipment	built-in motor temperature sensor					-
Optional equipment	moisture sensors in motor chamber and of water in oil					-
Guide type	PMP 50					-
Type of service crane	ZKU150 or ZKM150 with H or V base					-

The data above should only be used in conjunction with up to date and detailed information on www.biox.pl.

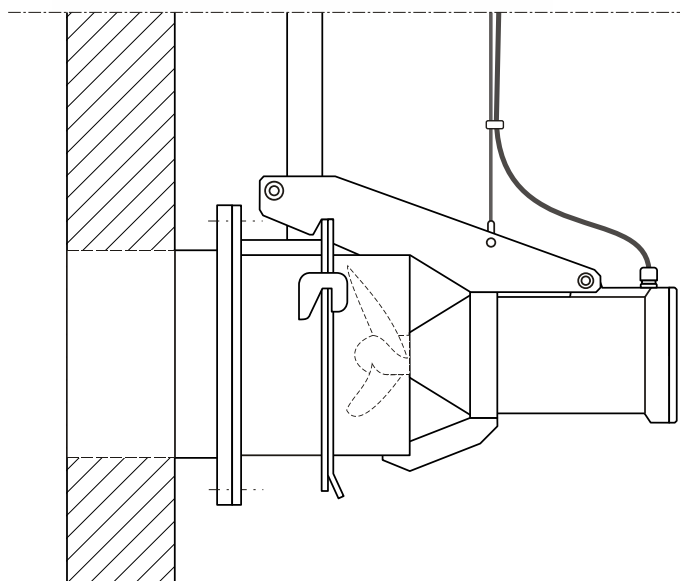

od 1989

mieszadła



natleniacze



dekantery



zbierracze



żurawiki



przewodnice



wciągarki