

MKP 15-55 TURBO PUMPING MIXERS

Medium-size submersible mixers adapted for operation as rotor pumps in installations requiring high performance, with a small lifting height.

They can work as pumping mixers after installation on coupling flanges supported by PMP guides with the use of service cranes.

Functions:

- pumping of liquid in pipelines,
- pumping of liquid between tanks with equalized levels

Mixer symbol	MKP15.6	MKP22.6	MKP30.6	MKP40.6	MKP55.6	Unit
Mixer power	1.5	2.2	3.0	4.0	5.5	kW
Revolutions	976	960	944	960	940	rpm
Rotor diameter	330-580					mm
Rotor type	rotor, tri-blade, self-cleaning					-
Pipeline size (DN)	350-600					mm
Pumping capacity	350	510	680	810	980	m ³ /h
Material	standard or acid-resistant (304 or 316 steel)					-
Seals	two-level mechanical sealing with oil chamber					-
Supply voltage	3x400					V
Weight	68.2	68.5	69.0	70.0	70.0	kg
Power cable	length 6 m (longer cable available upon request), standard or screened					
Recommended equipment	built-in motor temperature sensor					-
Optional equipment	moisture sensors in motor chamber and of water in oil					-
Guide type	PMP 60					
Type of service crane	ZKU150 or ZKM150 with H or V base					

The data above should only be used in conjunction with up to date and detailed information on www.biox.pl.

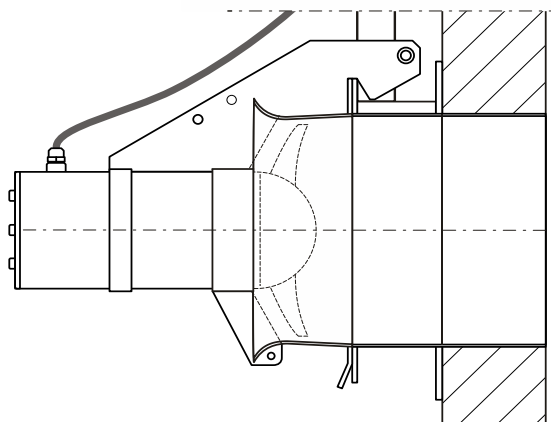

od 1989

mieszadła



natleniacze



dekantery



zbieracze



żurawiki



przewodnice



wciągarki